

# STAN Engineering

## PDM Series dosing and transfer pumps

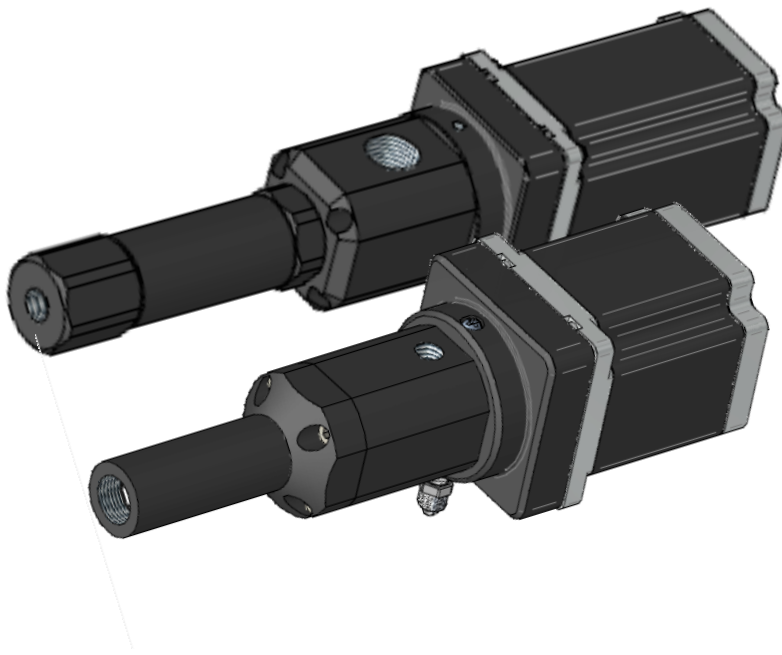

## Installation and service manual

## Summary

INTRODUCTION .....	3
Use compliance.....	4
Safety instructions .....	5
Technical description, function and assembly.....	6
Commissioning or starting up .....	8
General notice .....	8
Trials .....	8
How to avoid dry running.....	8
Position of the pump.....	8
Dosing and transferring.....	8
Commissioning.....	9
Pump speed table.....	11
Suck-back .....	11
Assembly and dismantling.....	12

## INTRODUCTION

Dear ladies and gentlemen!

First of all, we would like to congratulate you for buying STAN Engineering® products, allowing you to work with the latest technology. To be able to avoid malfunctions, some important criteria now follows for commissioning your STAN ENGINEERING® product and the servicing afterwards. Furthermore, we see it as our utmost duty to inform you about possible dangers in accordance with the operation of your new pump.

Therefore, please note, that this manual needs to be within the near of your service and other related personnel during, before and after operation of the pump.

We emphasise the need for reading this manual carefully and would like to point out, that important notices relating your security will follow within the next pages of this manual.

Understanding all notices and the technology related information allow you to operate your latest STAN Engineering® product without endangering yourself and others.

We wish you success and all the best with your newest STAN Engineering® Dosing product.

The STAN Engineering® dosing team

## Use compliance

Before operation, please carefully read the following

1. Please intensively study this manual before commissioning. Do get familiar with the operation manual before each start of the pump or every time when the operator changes.
2. Please note, that this manual is part of this particular pump even when being moved to another department or company.
3. The pump may only be used by healthy people
4. Do only use STAN Engineering<sup>®</sup> spare parts. Damages caused by using other parts are not supported by the STAN Engineering<sup>®</sup> warranty.
5. Should any of this manual not be clear or understandable, please do contact your distributor or write us under [info@stan-eng.it](mailto:info@stan-eng.it).

This pump is a self-priming endless dosing pump. Following materials may be used with it for metering or transferring:

- Adhesives and sealants with or without spheres
- Material resistant fluids and pastes
- Oils and lubricants
- Paints and lacquers

Do not use with cyanoacrylates, anaerobic glues, isocyanides, (M)ethyl Acetate or any explosion rated nor poisonous products. Please do contact your distributor for further information. We are not chemical specialists so please do check the pump material resistance of all wetted parts with your product supplier. Any improper use will produce the loss of the support of the STAN Engineering<sup>®</sup> warranty.

Explicit compliance for the pumped material:

Depending on the application, the maximum temperature may not exceed 120°C. With the use of aggressive products, please do always contact your distributor and product supplier to get approval before operation and or commissioning.

Make sure, that the local legislation has been incorporated all safety relevant demands are being kept.



Changes done by the user result in loss of warranty. All damage claims upon will be ignored. All safety relevant technical issues lose the STAN Engineering<sup>®</sup> warranty support.



**This sign shows a safety relevant message. Make sure all operator personnel and safety people take note or have been made aware.**

## Safety instructions



- Make sure, that you have taken care of the rules for accident prevention next to reading this manual.
- Do not disregard any caution sign; they give important notices to prevent accidents or injuries. Caution signs are an important part of the safety rules for accident prevention therefore need to be visible at all times.
- Before commissioning, please do check all screws and see if they are well tightened.
- Before starting to work with the pump, every worker needs to fully understand the application and its demands. Do not let the pump run without any supervision.
- Service and repairs may only be performed via trained personnel and the relevant tools.
- All needed accident prevention apparatus and fixtures must be installed before operation. Make sure they are in good condition at all times.
- Make sure that the pressure in the system has been neutralized while servicing the pump. Switch off the power.
- In case solvents are used, it may be needed to wear breathing protection masks. Please ask your safety staff.
- Never smell at openings after demounting the pump! 
- Take the needed precautions when working in an explosion proof zone! 
- Smoking is prohibited in the near of solvents and other inflammable products.
- Only work on the pump and the pump drive shaft when the power is off.
- Do not let the pump dry run.
- Make sure that the suction side connection is vacuum proof and that the connection of the pressure side is able to withstand the system pressure.
- Do not use demineralized water.

## Technical description, function and assembly

Basically, all STAN ENGINEERING® pumps can be used for dosing or transferring (pumping) or emptying applications:

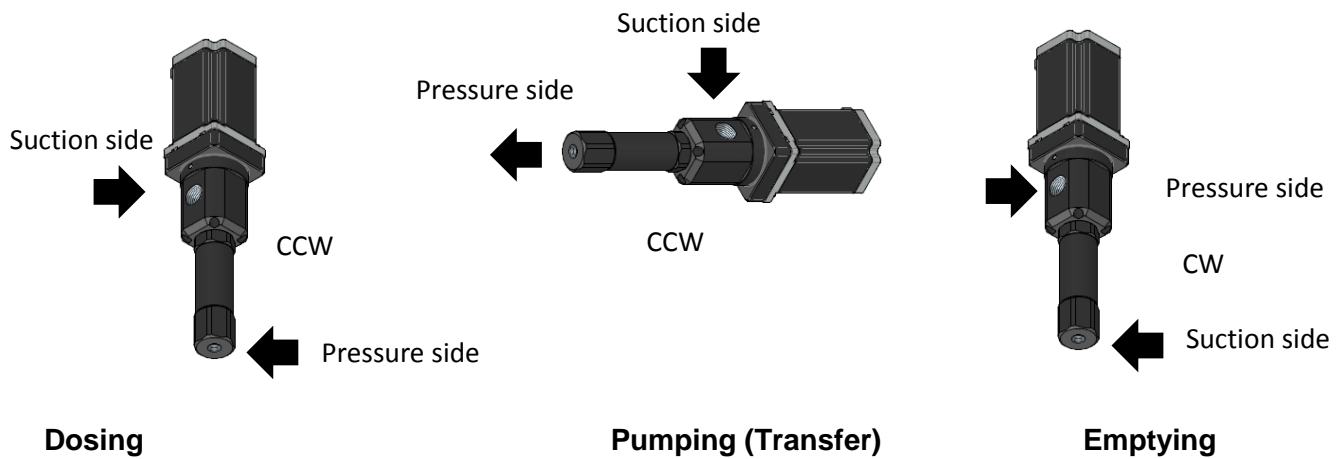

STAN ENGINEERING® pumps in general can be used in two directions: Clockwise or Counter Clockwise.

Furthermore, the position/angle of the pump almost does not have any effect on the pumping or dosing result. Only in some cases, the suction performance can be influenced by it.

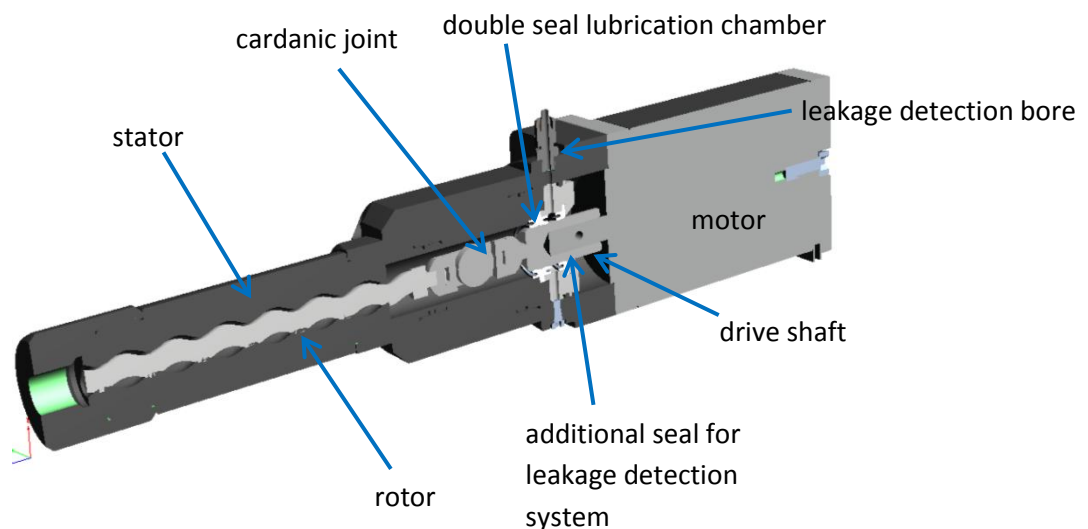

STAN Engineering® Dosing technology is based on the endless dosing progressing cavity pump. The rotating element “Rotor” and the static counterpart “Stator” form an optimal chamber “Cavity”. Both rotor and stator touch each other over the whole length to create a continuous seal that prevents backflow even with high back pressure. The movement of the rotating rotor in the stator allows the fluid to be gently pushed to the next chamber without shearing and squeezing the fluid. (picture 1).

Due to the fact that the cavity along the sealing line is always open, particles can be handled without difficulties. STAN Engineering® technology will pump and dose abrasive fluids but also more viscous pastes.

STAN Engineering® Rotors are manufactured to resist many chemical materials because of the STAN Engineering®-Fini-Coat, an ENP coating technique according FDA, USDA and NSF standards of conformity. The high degree of hardness of the rotor surface prevents fast wear and tear and provides long life cycle time.

STAN Engineering® Stators have been developed to offer less friction.

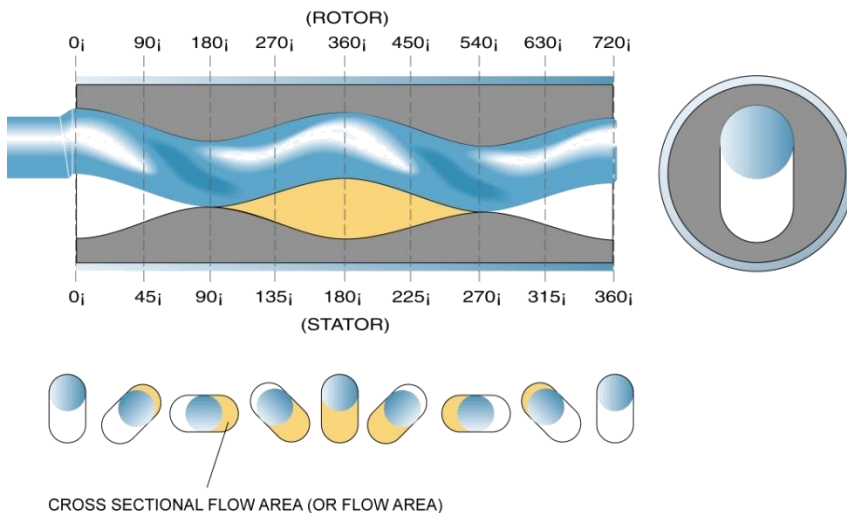

Picture 1:

Shows the possibility to convey particles and a gentle flow of the material (yellow).

The dosing volume is independent of the rotor(blue) position since the cavities have a defined volume.

Therefore, PCP technology is optimal for dispensing.

Driving the pump counter clockwise conveys the fluid or paste from the suction side towards the pressure side in picture 1 from left to right. To empty vessels or bottles, in general the flow should go from right to left meaning clockwise. STAN ENGINEERING pumps can be used in continuous or indexed applications.

**Avoid dry running!** 

## Commissioning or starting up

### General notice

- Make sure you are aware of the safety instructions under 1.2
- Make sure enough material is available
- Make sure all connections are well tightened
- Make sure all pump materials can resist the product

### Trials

Testing with water can cause loud noises and destroy the stator. Reason for this effect is the lack of lubrication with water. You may use glycol. Fluor elastomers such as Viton<sup>®</sup>, Viton Extreme are to be avoided with water.

Alternatively you may test with the product used for the application or also glycol or glycerin. Demineralized water should be avoided at all times because it may attack all pump materials. Please ask your distributor.

### How to avoid dry running

Since the rotor made of metal is running in an elastomeric rubber stator, heat can be produced when no material is being transported due to the lack of lubrication. There cannot be any heat dissipation because the rubber stator is working like a shield. A continuous friction builds up increasing heat that cannot be controlled therefore the stator material can be destroyed rapidly relative to the pump speed. Possible solution: Start the pump slowly at max. 10 rpm or pre-fill the pump.

### Position of the pump

Basically, all STAN Engineering<sup>®</sup> pumps can be positioned in any direction. Nevertheless, please consider the following:

**Dosing and transferring:** please do not exceed 10 bar pressure on the pump suction side for plastic pumps and 20 bar for the stainless steel version. Keep the inlet pressure constant to avoid bad dosing or transferring results. In case needed, use a pressure reduction valve. Please avoid continuous pressure peaks to reduce the stator wear. These values only refer to tests done with liquids at 3500 cps.

Back pressure:

High dosing pressures can be reached according the material viscosity and pump speed. Avoid **short** pressure peaks of > 30 bar (435 psi) for stainless steel pumps and > 20 bar (290 psi) for plastic pumps. Please adapt the nozzle, needle in length and/or hose diameter to decrease backpressure. By using conically shaped nozzle head setups, the backpressure



can be decreased. In case you use the pump for dosing, the suck-back feature can be optimized by using conically/tapered shaped exit adaptors.

**Notice:** We suggest using tapered needles whenever possible

Emptying: Stainless steel body pumps can be used up to 20 bar. Plastic versions should not be used above 10 bar. In both cases, you will be able to reduce the seal wear with lower pressure.

## Commissioning

### *Low viscous*

- Gently pre-fill the pump when possible, by using pressure steps. **Give the product enough time to flow!** (When available: Open the leakage control which you can find opposite of the material entrance which is sealed with an o-ring. As soon as material comes out of the bore, you may close the leakage bore).
- Start the pump (simultaneously for high viscous pastes) with low speed (5-10%) in manual mode (see further picture 1) until the material comes out thru the nozzle without air bubbles. It is wise to put the needle/nozzle after the bleeding process.

### *High viscous*

Before filling the pump, let it run 10 seconds with a very low speed to pump out the air. Then slowly start to fill the pump by giving little pressure to the material. As soon as the material leaves the needle without air bubbles, you may consider the pump to be well evacuated. Putting up the nozzle vertically, will allow the air to escape optimally.

- Position the pump horizontally with suction on top.
- fill the suction chamber with Vaseline oil and be sure to evacuate every small air bubble (by manually rotating the pump).

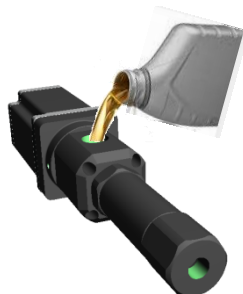

- start manually the pump in order to fill also the internal cavities. Use the 3mm hexagonal key and rotate counter clockwise until the product will come out from the pressure port, then refill the suction



- Screw the cartridge and apply the pressure

- Position vertically the pump with pressure way on top and start it at low speed (about 15 rpm) until the MS polymer starts to come out and all the air bubbles are evacuated. In the end, if in the application is required turn the pump in the right way.

Fig. A

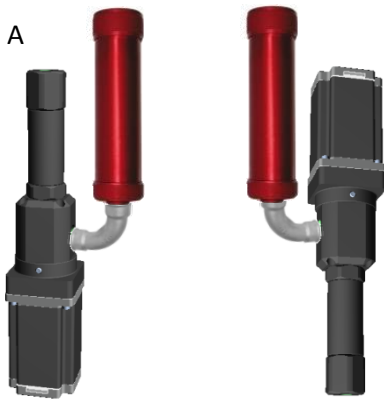
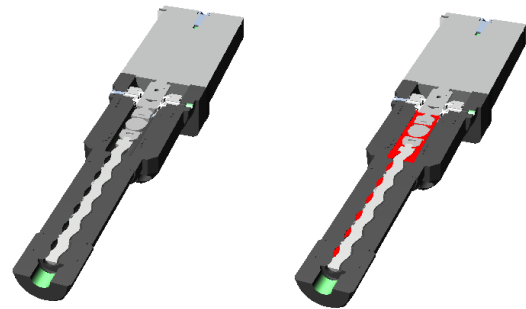

Fig. B



- Do not remove or reduce the pressure over the night or over the week end
- Never start the pump without the right inlet pressure
- Do not perform too long suck back, the pump may introduce air inside
- Generally, avoid air entering inside the pump
- When not used, always ensure to perfectly close suction and delivery ways
- In case of long stops or requirement to disconnect the air pressure disassemble the pump and clean it

## Pump speed table

Following values are only an orientation support:

Product (cP ≈ mPa.s)	Pump speed	Suction pressure
Water like fluids	Till 100%	Ambient or max. 1-2 bar
Honey like pastes	Max. 90%	4-5 bar
Oils, greases till 25.000 mPa.s	Max. 70%	5-7 bar
Oils, greases till 50.000 mPa.s	Max. 50%	10-12 bar
Silicone und Epoxies not filled	Max. 80%	12-15 bar
Silicone und Epoxies filled	Max. 60%	12-15 bar
UV-adhesives	Max. 90%	4-5 bar
Pastes till 50.000 mPa.s	Max. 50%	12-15 bar
Pastes over 50.000 mPa.s	Max. 50%	Max. 20 bar (only stainless steel pumps)

In almost all applications, the material flow-ability is essential for a good dosing result. Make sure, that the pumps cavities are completely filled at max. dosing speed. The material flow-ability sets the pump speed therefore do not just start the pump without thinking about the rheology of the product. The suction side pressure and pressure side back pressure together with the dosing velocity are key for the long life time of your STAN Engineering® pump.

## Suck-back

This feature allows you to control the after-dripping or offers you the possibility to achieve a good dispensed bead end:



1. choose the amount of steps according the viscosity and nozzle setup
2. set the speed according the viscosity. Please note, that fast speeds do not always mean, that you will be able to stop the fluid fast. This will depend on the nozzle/needle setup. Water like products do not need many steps but higher speeds.

Assembly and dismantling

# PDM 17

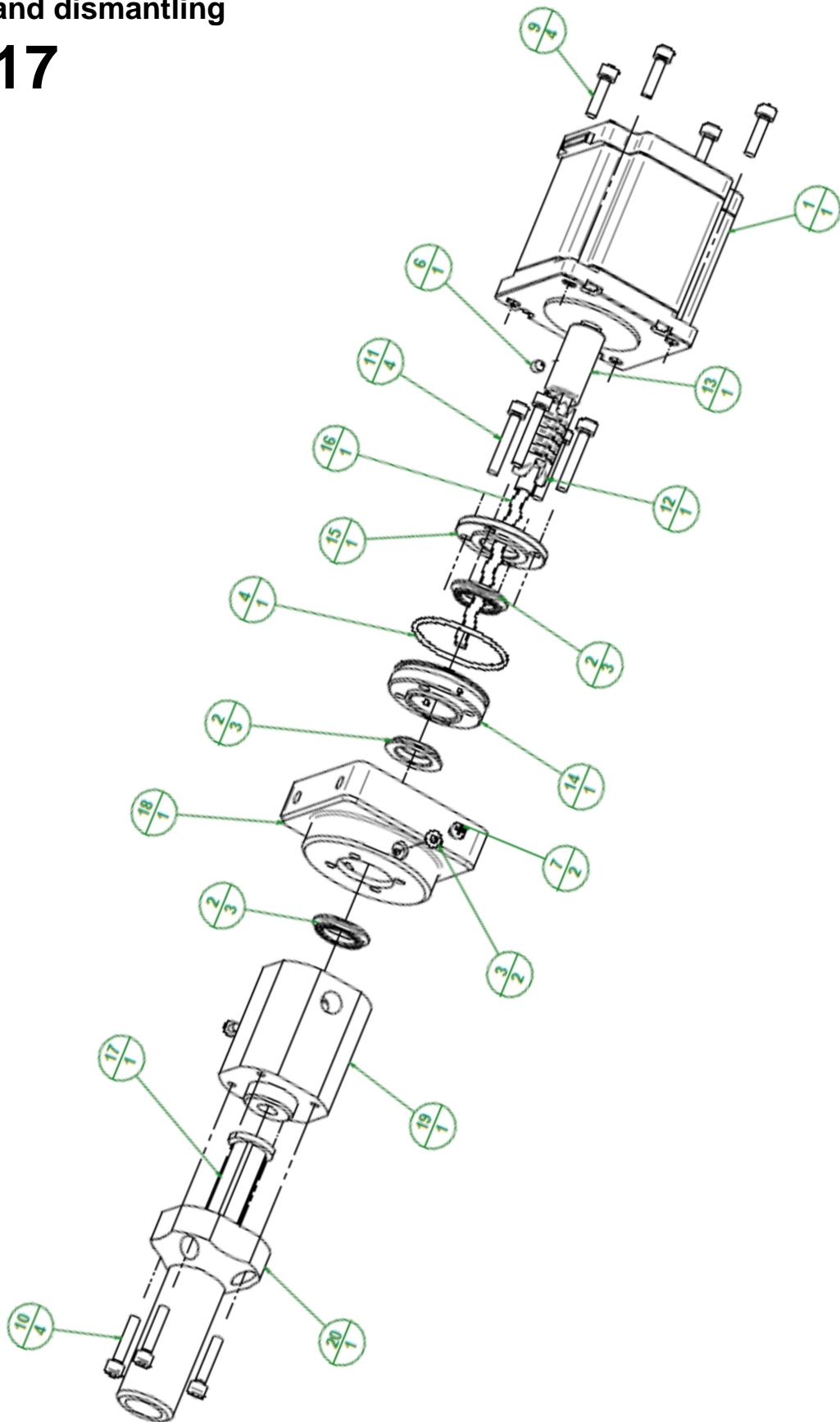

**PDM17.000.X - PDM 17 with stainless steel body**

Num.	Codice/Code	Rev.	Titolo	Titolo	Qtà	Categoria/Category	Oggetto/Object	Materiale/Material
1	MRST25-65-A8C		Motore step tg.24 h65 albero spianato $\varnothing$ e 8 - con connettore	Stepping motor sized 24 h65 surfaced shaft $\varnothing$ e 8 - with connector	1	Elettrico	Commercial e	Alluminio Step
2	GUA REL V14PEHD		Guarnizione albero 14X19/23X3.6 PEHD70 MOLLA AISI 302	Shaft seal 14X19/23X3.6 PEHD70s with spring AISI 302	3	Guarnizioni	Commercial e	PEHD70
3	GUA VIOR2010		Guarnizione or viton 2010 diam int2.57 corda 1.78		2	Guarnizioni	Commercial e	Viton
4	GUA VIOR2137		Guarnizione OR viton 2137 diam int 34,65 corda 1,78	Gasket OR viton 2137 diams int 34,65 rope 1,78	1	Guarnizioni	Commercial e	Viton
5	SPPCA 03012		Spina cilindrica acciaio 3x12 ISO 8734A temprata	Cylindrical lockpin 3x12 ISO 8734A (Stainless steel hardened)	2	Meccanica	Commercial e	AISI 304
6	VI GRPCBM04X06		Grano punta conica uni5927 brunito m04x06	Grub screw cone-shaped point M4x06mm (Burnished) UNI5927	1	Viteria	Commercial e	Acciaio
7	VI TBCIZM03X04		Vite testa bombata croce incassata M3x4mm Zincata	Roundheaded cross-slotted screw M3x4mm (ZincPlated)	2	Viteria	Commercial e	Fe Zn
8	VI TCEIZM04X08-12.9		Vite tcei uni5931 M4x8 in acciaio 12.9	Cheese-headed screw M4x8mm (12.9 steel) UNI 5931	1	Viteria	Commercial e	Fe Zn
9	VI TCEIZM04X16		Vite tcei uni5931 zincata m04x16	Cheese-headed screw M4x16mm (Galvanized) UNI 5931	4	Viteria	Commercial e	Fe Zn
10	VI TCEIZM04X20		Vite tcei uni5931 zincata m04x20	Cheese-headed screw M4x20mm (Galvanized) UNI 5931	4	Viteria	Commercial e	Fe Zn
11	VI TCEIZM04X25		Vite tcei uni5931 zincata m04x25	Cheese-headed screw M4x25mm (Galvanized) UNI 5931	4	Viteria	Commercial e	Fe Zn
12	RTR.02.001		Giunto snodato - Accoppiamento motore	Articulated joint-coupling engine	1	Giunti	Particolare a disegno	Nylon
13	PDM70.02.003		Adattatore motore/giunto	Adapter motor/joint	1	Meccanica	Particolare a disegno	AISI 430
14	PDM70.007 1	1	Flangia bloccaggio guarnizioni	Blocking flange for shaft seals	1	Meccanica	Particolare a disegno	Delrin nero
15	PDM70.008 1	1	Flangia 2 bloccaggio guarnizione	Blocking flange 2 for shaft seal	1	Meccanica	Particolare a disegno	Delrin nero
16	RTR.03.001		Rotore pompa monovite (0,2cc)	Rotor of the pump (0,2cc)	1	Meccanica	Particolare a disegno	Acciaio AVP
17	PCP01.002.EV		Statore in Viton® Extreme™ ETP-600S	Stator (Viton® Extreme™ ETP-600S)	1	Pompe	Particolare a disegno	Viton® Extreme™
18	PDM17.001.X		Blocco per tenuta	Block for seal	1	Pompe	Particolare a disegno	AISI 316
19	PDM17.002.X		Camera aspirazione	Suction chamber	1	Pompe	Particolare a disegno	AISI 316
20	PDM17.003.X		Carter statore	Carter for stator	1	Pompe	Particolare a disegno	AISI 316

**PDM17.000.D - PDM 17 with HD POM body**

Num.	Codice/Code	Rev.	Titolo	Title	Qtà	Categoria/Category	Oggetto/Object	Materiale/Material
1	MRST25-65-A8C		Motore step tg.24 h65 albero spianato Øe 8 - con connettore	Stepping motor sized 24 h65 surfaced shaft Øe 8 - with connector	1	Elettrico	Commercia le	Alluminio Step
2	GUA REL V14PEHD		Guarnizione albero 14X19/23X3.6 PEHD70 MOLLA AISI 302	Shaft seal 14X19/23X3.6 PEHD70s with spring AISI 302	3	Guarnizioni	Commercia le	PEHD70
3	GUA VIOR2010		Guarnizione or viton 2010 diam int2.57 corda 1.78		2	Guarnizioni	Commercia le	Viton
4	GUA VIOR2137		Guarnizione OR viton 2137 diam int 34,65 corda 1,78	Gasket OR viton 2137 diams int 34,65 rope 1,78	1	Guarnizioni	Commercia le	Viton
5	SPPCA 03012		Spina cilindrica acciaio 3x12 ISO 8734A temprata	Cylindrical lockpin 3x12 ISO 8734A (Stainless steel hardened)	2	Meccanica	Commercia le	AISI 304
6	VI GRPCBM04 X06		Grano punta conica uni5927 brunito m04x06	Grub screw cone-shaped point M4x06mm (Burnished) UNI5927	1	Viteria	Commercia le	Acciaio
7	VI TBCIZM03X 04		Vite testa bombata croce incassata M3x4mm Zincata	Roundheaded cross-slotted screw M3x4mm (ZincPlated)	2	Viteria	Commercia le	Fe Zn
8	VI TCEIZM04X 08-12.9		Vite tcei uni5931 M4x8 in acciaio 12.9	Cheese-headed screw M4x8mm (12.9 steel) UNI 5931	1	Viteria	Commercia le	Fe Zn
9	VI TCEIZM04X 16		Vite tcei uni5931 zincata m04x16	Cheese-headed screw M4x16mm (Galvanized) UNI 5931	4	Viteria	Commercia le	Fe Zn
10	VI TCEIZM04X 20		Vite tcei uni5931 zincata m04x20	Cheese-headed screw M4x20mm (Galvanized) UNI 5931	4	Viteria	Commercia le	Fe Zn
11	VI TCEIZM04X 25		Vite tcei uni5931 zincata m04x25	Cheese-headed screw M4x25mm (Galvanized) UNI 5931	4	Viteria	Commercia le	Fe Zn
12	RTR.02.001		Giunto snodato - Accoppiamento motore	Articulated joint-coupling engine	1	Giunti	Particolare a disegno	Nylon
13	PDM70.02.003		Adattatore motore/giunto	Adapter motor/joint	1	Meccanica	Particolare a disegno	AISI 430
14	PDM70.007 1	1	Flangia bloccaggio guarnizioni	Blocking flange for shaft seals	1	Meccanica	Particolare a disegno	Delrin nero
15	PDM70.008 1	1	Flangia 2 bloccaggio guarnizione	Blocking flange 2 for shaft seal	1	Meccanica	Particolare a disegno	Delrin nero
16	RTR.03.001		Rotore pompa monovite (0,2cc)	Rotor of the pump (0,2cc)	1	Meccanica	Particolare a disegno	Acciaio AVP
17	PCP01.002. EV		Statore in Viton® Extreme™ ETP-600S	Stator (Viton® Extreme™ ETP-600S)	1	Pompe	Particolare a disegno	Viton® Extreme™
18	PDM17.001 .D		Blocco per tenuta	Block for seal	1	Pompe	Particolare a disegno	Delrin nero
19	PDM17.002 .D		Camera aspirazione	Suction chamber	1	Pompe	Particolare a disegno	Delrin nero
20	PDM17.003 .D		Carter statore	Carter for stator	1	Pompe	Particolare a disegno	Delrin nero

# PDM 70 and PDM 80

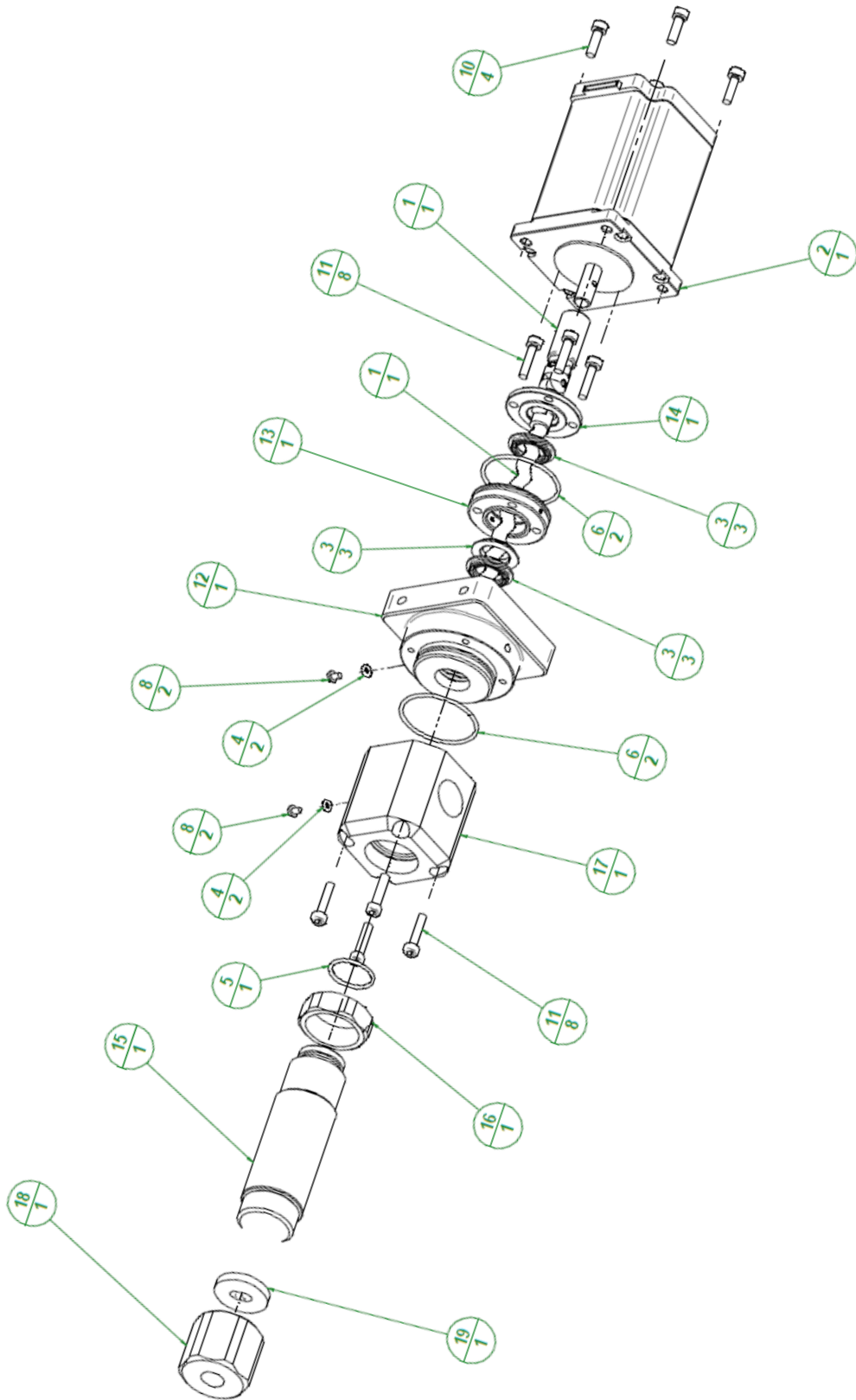

**PDM70.000.X - PDM 70 with stainless steel body**

Num.	Codice/Code	Rev.	Titolo	Title	Qtà	Categoria/Category	Oggetto/Object	Materiale/Material
1	PDM70.02.200		Giunto motore/rotore completo - 0,85 ml	Coupling motor/rotor (complete assembly) - 0,85 ml	1	Assemblaggi o	Assieme	
2	MRST60SH86		Motore step tg.24 h86 albero spianato Øe 8 - con connettore	Stepping motor sized 24 h65 surfaced shaft Øe 8 - with connector	1	Elettrico	Commercia le	Alluminio Step
3	GUA REL V14PEHD		Guarnizione albero 14X19/23X3.6 PEHD70 MOLLA AISI 302	Shaft seal 14X19/23X3.6 PEHD70s with spring AISI 302	3	Guarnizioni	Commercia le	PEHD70
4	GUA VIOR2010		Guanizione or viton 2010 diam int2.57 corda 1.78		2	Guarnizioni	Commercia le	Viton
5	GUA VIOR2075		Guanizione or viton 2075 diam int. 18,77 corda 1,78 Or 2087	Viton Øi 18,77 rope 1,78	1	Guarnizioni	Commercia le	Viton
6	GUA VIOR2137		Guarnizione OR viton 2137 diam int 34,65 corda 1,78	Gasket OR viton 2137 diams int 34,65 rope 1,78	2	Guarnizioni	Commercia le	Viton
7	VI GRPCBM04X06		Grano punta conica uni5927 brunito m04x06	Grub screw cone-shaped point M4x06mm (Burnished) UNI5927	1	Viteria	Commercia le	Acciaio
8	VI TBCIZM03X04		Vite testa bombata croce incassata M3x4mm Zincata	Roundheaded cross-slotted screw M3x4mm (ZincPlated)	2	Viteria	Commercia le	Fe Zn
9	VI TCEIZM04X08-12.9		Vite tcei uni5931 M4x8 in acciaio 12.9	Cheese-headed screw M4x8mm (12.9 steel) UNI 5931	1	Viteria	Commercia le	Fe Zn
10	VI TCEIZM04X16		Vite tcei uni5931 zincata m04x16 Cheese-headed	screw M4x16mm (Galvanized) UNI 5931	4	Viteria	Commercia le	Fe Zn
11	VI TCEIZM04X20		Vite tcei uni5931 zincata m04x20 Cheese-headed	screw M4x20mm (Galvanized) UNI 5931	8	Viteria	Commercia le	Fe Zn
12	PDM70.001.X	2	Blocco per tenuta	Block for seal	1	Particolare meccanico	Particolare a disegno	AISI 316
13	PDM70.007	1	Flangia bloccaggio guarnizioni	Blocking flange for shaft seals	1	Particolare meccanico	Particolare a disegno	Delrin nero
14	PDM70.008	1	Flangia 2 bloccaggio guarnizione	Blocking flange 2 for shaft seal	1	Particolare meccanico	Particolare a disegno	Delrin nero
15	PDM70.002.X	3	Cannotto per statore	Sleeve stator	1	Pompe	Particolare a disegno	AISI 316
16	PDM70.003.X	1	Ghiera di bloccaggio	Locking ring	1	Pompe	Particolare a disegno	AISI 316
17	PDM70.005.X	1	Blocco per aspirazione PDM70 1/2"	Block for suction PDM70 1/2"	1	Pompe	Particolare a disegno	AISI 316
18	PDM70.006.X		Nipplo con attacco G1/4"	Nipple with fitting G1/4"	1	Pompe	Particolare a disegno	AISI 316
19	PDM70.01.002		Statore in Extreme Viton (209-0014199-0.1A)	Stator (Extreme Viton) (209-0014199-0.1A)	1	Pompe	Particolare a disegno	Extreme-Viton



**PDM70.000.X - PDM 70 with HD POM body**

Num.	Codice/Code	Rev.	Titolo	Title	Qtà	Categoria/Category	Oggetto/Object	Materiale/Material
1	PDM70.02.200		Giunto motore/rotore completo - 0,85 ml	Coupling motor/rotor (complete assembly) - 0,85 ml	1	Assemblaggio	Assieme	
2	MRST60SH86		Motore step tg.24 h86 albero spianato Øe 8 - con connettore	Stepping motor sized 24 h65 surfaced shaft Øe 8 - with connector	1	Elettrico	Commercia le	Alluminio Step
3	GUA REL V14PEHD		Guarnizione albero 14X19/23X3.6 PEHD70 MOLLA AISI 302	Shaft seal 14X19/23X3.6 PEHD70s with spring AISI 302	3	Guarnizioni	Commercia le	PEHD70
4	GUA VIOR2010		Guanizione or viton 2010 diam int.2.57 corda 1.78		2	Guarnizioni	Commercia le	Viton
5	GUA VIOR2075		Guanizione or viton 2075 diam int. 18,77 corda 1,78 Or 2087	Viton Øi 18,77 rope 1,78	1	Guarnizioni	Commercia le	Viton
6	GUA VIOR2137		Guarnizione OR viton 2137 diam int 34,65 corda 1,78	Gasket OR viton 2137 diams int 34,65 rope 1,78	2	Guarnizioni	Commercia le	Viton
7	VI GRPCBM04 X06		Grano punta conica uni5927 brunito m04x06	Grub screw cone-shaped point M4x06mm (Burnished) UNI5927	1	Viteria	Commercia le	Acciaio
8	VI TBCIZM03X04		Vite testa bombata croce incassata M3x4mm Zincata	Roundheaded cross-slotted screw M3x4mm (ZincPlated)	2	Viteria	Commercia le	Fe Zn
9	VI TCEIZM04X08-12.9		Vite tcei uni5931 M4x8 in acciaio 12.9	Cheese-headed screw M4x8mm (12.9 steel) UNI 5931	1	Viteria	Commercia le	Fe Zn
10	VI TCEIZM04X16		Vite tcei uni5931 zincata m04x16 Cheese-headed	screw M4x16mm (Galvanized) UNI 5931	4	Viteria	Commercia le	Fe Zn
11	VI TCEIZM04X20		Vite tcei uni5931 zincata m04x20 Cheese-headed	screw M4x20mm (Galvanized) UNI 5931	8	Viteria	Commercia le	Fe Zn
12	PDM70.001.D	2	Blocco per tenuta	Block for seal	1	Particolare meccanico	Particolare a disegno	HD POM
13	PDM70.007	1	Flangia bloccaggio guarnizioni	Blocking flange for shaft seals	1	Particolare meccanico	Particolare a disegno	HD POM
14	PDM70.008	1	Flangia 2 bloccaggio guarnizione	Blocking flange 2 for shaft seal	1	Particolare meccanico	Particolare a disegno	HD POM
15	PDM70.002.D	3	Cannotto per statore	Sleeve stator	1	Pompe	Particolare a disegno	HD POM
16	PDM70.003.D	1	Ghiera di bloccaggio	Locking ring	1	Pompe	Particolare a disegno	HD POM
17	PDM70.005.D	1	Blocco per aspirazione PDM70 1/2"	Block for suction PDM70 1/2"	1	Pompe	Particolare a disegno	HD POM
18	PDM70.006.D		Nipallo con attacco G1/4"	Nipple with fitting G1/4"	1	Pompe	Particolare a disegno	HD POM
19	PDM70.01.002		Statore in Extreme Viton (209-0014199-0.1A)	Stator (Extreme Viton) (209-0014199-0.1A)	1	Pompe	Particolare a disegno	Extreme-Viton

**PDM80.000.X - PDM 80 with stainless steel body**

Num.	Codice/Code	Rev.	Titolo	Title	Qtà	Categoria/Category	Oggetto/Object	Materiale/Material
1	PDM80.02.200		Giunto motore/rotore completo – 1,78 ml	Coupling motor/rotor (complete assembly) – 1,78 ml	1	Assemblaggio	Assieme	
2	MRST60SH86		Motore step tg.24 h86 albero spianato Øe 8 - con connettore	Stepping motor sized 24 h65 surfaced shaft Øe 8 - with connector	1	Elettrico	Commercia le	Alluminio Step
3	GUA REL V14PEHD		Guarnizione albero 14X19/23X3.6 PEHD70 MOLLA AISI 302	Shaft seal 14X19/23X3.6 PEHD70s with spring AISI 302	3	Guarnizioni	Commercia le	PEHD70
4	GUA VIOR2010		Guarnizione or viton 2010 diam int.2.57 corda 1.78		2	Guarnizioni	Commercia le	Viton
5	GUA VIOR2075		Guarnizione or viton 2075 diam int. 18,77 corda 1,78 Or 2087	Viton Øi 18,77 rope 1,78	1	Guarnizioni	Commercia le	Viton
6	GUA VIOR2137		Guarnizione OR viton 2137 diam int 34,65 corda 1,78	Gasket OR viton 2137 diams int 34,65 rope 1,78	2	Guarnizioni	Commercia le	Viton
7	VI GRPCBM04 X06		Grano punta conica uni5927 brunito m04x06	Grub screw cone-shaped point M4x06mm (Burnished) UNI5927	1	Viteria	Commercia le	Acciaio
8	VI TBCIZM03X 04		Vite testa bombata croce incassata M3x4mm Zincata	Roundheaded cross-slotted screw M3x4mm (ZincPlated)	2	Viteria	Commercia le	Fe Zn
9	VI TCEIZM04X 08-12.9		Vite tcei uni5931 M4x8 in acciaio 12.9	Cheese-headed screw M4x8mm (12.9 steel) UNI 5931	1	Viteria	Commercia le	Fe Zn
10	VI TCEIZM04X 16		Vite tcei uni5931 zincata m04x16 Cheese-headed	screw M4x16mm (Galvanized) UNI 5931	4	Viteria	Commercia le	Fe Zn
11	VI TCEIZM04X 20		Vite tcei uni5931 zincata m04x20 Cheese-headed	screw M4x20mm (Galvanized) UNI 5931	8	Viteria	Commercia le	Fe Zn
12	PDM70.001.X	2	Blocco per tenuta	Block for seal	1	Particolare meccanico	Particolare a disegno	HD POM
13	PDM70.007	1	Flangia bloccaggio guarnizioni	Blocking flange for shaft seals	1	Particolare meccanico	Particolare a disegno	HD POM
14	PDM70.008	1	Flangia 2 bloccaggio guarnizione	Blocking flange 2 for shaft seal	1	Particolare meccanico	Particolare a disegno	HD POM
15	PDM70.002.X	3	Cannotto per statore	Sleeve stator	1	Pompe	Particolare a disegno	HD POM
16	PDM70.003.X	1	Ghiera di bloccaggio	Locking ring	1	Pompe	Particolare a disegno	HD POM
17	PDM70.005.X	1	Blocco per aspirazione PDM70 1/2"	Block for suction PDM70 1/2"	1	Pompe	Particolare a disegno	HD POM
18	PDM70.006.X		Nipplo con attacco G1/4"	Nipple with fitting G1/4"	1	Pompe	Particolare a disegno	HD POM
19	PDM80.01.002		Statore in Extreme Viton (209-0014199-0.1A)	Stator (Extreme Viton) (209-0014199-0.1A)	1	Pompe	Particolare a disegno	Extreme-Viton

**PDM80.000.D - PDM 80 with HD POM body**

Num.	Codice/Code	Rev.	Titolo	Title	Qtà	Categoria/Category	Oggetto/Object	Materiale/Material
1	PDM80.02.200		Giunto motore/rotore completo - 1,78 ml	Coupling motor/rotor (complete assembly) - 1,78 ml	1	Assemblaggio	Assieme	
2	MRST60SH86		Motore step tg.24 h86 albero spianato Øe 8 - con connettore	Stepping motor sized 24 h65 surfaced shaft Øe 8 - with connector	1	Elettrico	Commerciale	Alluminio Step
3	GUA REL V14PEHD		Guarnizione albero 14X19/23X3.6 PEHD70 MOLLA AISI 302	Shaft seal 14X19/23X3.6 PEHD70s with spring AISI 302	3	Guarnizioni	Commerciale	PEHD70
4	GUA VIOR2010		Guanizione or viton 2010 diam int.2.57 corda 1.78		2	Guarnizioni	Commerciale	Viton
5	GUA VIOR2075		Guanizione or viton 2075 diam int. 18,77 corda 1,78 Or 2087	Viton Øi 18,77 rope 1,78	1	Guarnizioni	Commerciale	Viton
6	GUA VIOR2137		Guarnizione OR viton 2137 diam int 34,65 corda 1,78	Gasket OR viton 2137 diam int 34,65 rope 1,78	2	Guarnizioni	Commerciale	Viton
7	VI GRPCBM04X06		Grano punta conica uni5927 brunito m04x06	Grub screw cone-shaped point M4x06mm (Burnished) UNI5927	1	Viteria	Commerciale	Acciaio
8	VI TBCIZM03X04		Vite testa bombata croce incassata M3x4mm Zincata	Roundheaded cross-slotted screw M3x4mm (ZincPlated)	2	Viteria	Commerciale	Fe Zn
9	VI TCEIZM04X08-12.9		Vite tcei uni5931 M4x8 in acciaio 12.9	Cheese-headed screw M4x8mm (12.9 steel) UNI 5931	1	Viteria	Commerciale	Fe Zn
10	VI TCEIZM04X16		Vite tcei uni5931 zincata m04x16 Cheese-headed	screw M4x16mm (Galvanized) UNI 5931	4	Viteria	Commerciale	Fe Zn
11	VI TCEIZM04X20		Vite tcei uni5931 zincata m04x20 Cheese-headed	screw M4x20mm (Galvanized) UNI 5931	8	Viteria	Commerciale	Fe Zn
12	PDM70.001.D	2	Blocco per tenuta	Block for seal	1	Particolare meccanico	Particolare a disegno	HD POM
13	PDM70.007	1	Flangia bloccaggio guarnizioni	Blocking flange for shaft seals	1	Particolare meccanico	Particolare a disegno	HD POM
14	PDM70.008	1	Flangia 2 bloccaggio guarnizione	Blocking flange 2 for shaft seal	1	Particolare meccanico	Particolare a disegno	HD POM
15	PDM70.002.D	3	Cannotto per statore	Sleeve stator	1	Pompe	Particolare a disegno	HD POM
16	PDM70.003.D	1	Ghiera di bloccaggio	Locking ring	1	Pompe	Particolare a disegno	HD POM
17	PDM70.005.D	1	Blocco per aspirazione PDM70 1/2"	Block for suction PDM70 1/2"	1	Pompe	Particolare a disegno	HD POM
18	PDM70.006.D		Nipplo con attacco G1/4"	Nipple with fitting G1/4"	1	Pompe	Particolare a disegno	HD POM
19	PDM80.01.002		Statore in Extreme Viton (209-0014199-0.1A)	Stator (Extreme Viton) (209-0014199-0.1A)	1	Pompe	Particolare a disegno	Extreme-Viton